

Issue Date: 05-08-2009
Revision Date: 03-27-2025
Renewal Date: 03-31-2026

DIVISION: 06 00 00 – WOOD, PLASTIC AND COMPOSITES
Section: 06 63 00 – Plastic Railings

REPORT HOLDER:
VEKA, INC.
100 VEKA Drive
Fombell, PA 16123
(800) 654-5589
www.vekaoutdoorliving.com

REPORT SUBJECT:
VEKA Vinyl Guard Systems:

- *Conrad System*
- *Genova System*
- *Genova II System*
- *London System*
- *Deck Teck System*
- *Duralux T System*
- *Majestic System*
- *Potenza System*
- *Potenza II System*
- *Prestige System*
- *Regal System*
- *Stanfield System*
- *Stanfield II System*
- *Trustin System*
- *Trustin II System*
- *Whitman System*

Additional Listee:

Great Railing, Inc.
1086 North Black Horse Pike
Williamstown, NJ 08094
(856) 875-0050

- All Models

Greenway Fence & Railing Supply
601 Overlas Grove Road
New Holland, PA 17557
(717) 354-8098
Limited to the following Models:

- *Genova System*
- *Genova II System*
- *Majestic System*
- *Potenza System*
- *Potenza II System*

1.0 SCOPE OF EVALUATION

1.1 This Research Report addresses compliance with the following Codes:

- 2024, 2021, and 2018 *International Building Code*® (IBC)
- 2024, 2021, and 2018 *International Residential Code*® (IRC)

NOTE: This report references the most recent Code editions noted. Section numbers in earlier editions may differ.

1.2 VEKA Vinyl Guard Systems have been evaluated for the following properties:

- Structural Performance
- Durability
- Surface Burning
- Decay Resistance
- Termite Resistance

1.3 VEKA Vinyl Guard Systems have been evaluated for the following uses (see Table 1):

- The VEKA Vinyl Guard Systems described in this report are guards and guards under the definitions of the referenced codes. They are intended for use at or near the open sides of elevated walking areas of buildings and walkways as required by the referenced codes.
- Guard systems recognized in this report may be used in One- and Two-Family Dwellings regulated by the IRC and all construction types regulated by the IBC in accordance with IBC Sections 705.2.2 and 705.2.3.1, Exceptions 2 and 3. Guards less than 42 inches high are limited to use in One- and Two-Family Dwellings (IRC). See Table 1 for additional restrictions based upon Use and Occupancy Classification.



2.0 STATEMENT OF COMPLIANCE

VEKA Vinyl Guard Systems comply with the Codes listed in Section 1.1, for the properties stated in Section 1.2 and uses stated in Section 1.3, when installed as described in this report, including the Conditions of Use stated in Section 6.

2.1 2024 IBC and IRC Evaluation Reports

The Intertek CCRR is an Evaluation Report for approval of an alternate material, design, or method of construction in accordance with Section 104.2.3.6.1 of the 2024 IBC and Section R104.2.2.6.1 of the 2024 IRC.

3.0 DESCRIPTION

3.1 Guard systems include a top and bottom rail, with or without aluminum inserts (See Tables 1 and 2), vertical balusters, post sleeves, rail-to-post brackets, foot blocks and decorative moldings.

3.2 Rails, post sleeves, foot blocks, balusters and decorative moldings are Polyvinyl Chloride (PVC). PVC components are produced in three colors: White, Almond or Khaki. Galvanized, powder-coated iron balusters are also utilized and produced in various colors.

3.3 All top rails are provided with an aluminum insert (See Tables 1 and 2, and Figure 2).

3.4 The bottom rail is supplied with or without an aluminum insert (See Table 1 and Figure 2).

3.5 Level guards with heights of 36 inches or 42 inches above the floor surface are provided in lengths up to 10 feet as measured from inside-to-inside of supports. See Tables 1 and 2.

3.6 The top assembly consists of one rail and is attached to each support with a single bracket. The top rail may be a T-shape, an ornamental shape or a rectangular shape. See Figure 1.

3.7 The bottom assembly consists of one rail and is attached to each support with a single bracket. The bottom rail is a rectangular shape measuring 2 inches wide and 3.5 inches deep. See Figure 1.

3.8 Balusters are blow-molded PVC, co-extruded PVC, galvanized powder-coated iron, or aluminum and are

supplied in various dimensions and styles. The balusters are placed through routed openings in both the top and bottom rails to provide a means for securing the balusters in the rails. See Figures 3 through 5.

3.9 The baluster spacing resulting from assemblies recognized in this report shall provide spacing such that a 4 inch diameter sphere cannot pass through any opening between balusters.

3.10 Post sleeves are 4 inches square and have a wall thickness of either 0.16 inch or 0.135 inch. See Figure 6.

3.11 The mounting brackets are made of molded plastic/nylon, die cast zinc or aluminum with a plastic cover. See Tables 1, 2, and Figure 7.

4.0 PERFORMANCE CHARACTERISTICS

4.1 The guard systems described in this report have demonstrated the capacity to resist the design loadings specified in Chapter 16 of the IBC and Section R301 of the IRC when tested in accordance with ICC-ES AC174.

4.2 Structural performance has been demonstrated for a temperature range from -20°F to 125°F.

4.3 Materials used are deemed equivalent to preservative treated or naturally durable wood for resistance to weathering effects, decay, and attack from termites.

4.4 All components have a flame spread not exceeding 200 when tested according to ASTM E84.

5.0 INSTALLATION

5.1 General:

VEKA Vinyl Guard Systems must be installed in accordance with the manufacturer's published installation instructions, the applicable Code, and this Research Report. A copy of the manufacturer's instructions must be available on the jobsite during installation.

5.2 The top and bottom rail assemblies are attached to PVC sleeved conventional wood posts or other supporting structure with a mounting bracket. See Tables 1 and 2.





5.3 One mounting bracket attaches to each end of the upper rail. The brackets are attached to the supports. See Tables 1, 2 and 4 for attachment details.

5.4 One mounting bracket attaches to each end of the lower rail. The brackets are attached to the supports. See Tables 1, 2 and 4 for attachment details.

5.5 Foot blocks are intermediate bottom rail supports and are installed between the deck surface and the rail for all with exception of the Deck Teck and Prestige systems. Two supports are used for the 10-foot rail systems and are located at the one-third points. The 6- and 8-foot rail systems utilize one intermediate support located at the mid-point.

5.6 The wood in the supporting structure including support posts shall have a specific gravity of 0.55 or greater (Southern Yellow Pine or better) and a minimum thickness to allow full penetration of the bracket mounting screws.

6.0 CONDITIONS OF USE

6.1 Installation must comply with this Research Report, the manufacturer’s published installation instructions, and the applicable Code. In the event of a conflict, this report governs.

6.2 The guard assemblies identified in this report are deemed to comply with the intent of the provisions of the referenced building codes subject to the following conditions:

6.2.1 Guards recognized in this report and regulated by the IBC or IRC are limited to exterior use in all construction types where combustible materials are permitted in accordance with Section 705.2 of the IBC and in One- and Two-Family Dwellings regulated by the IRC.

6.2.2 Conventional wood supports including support posts for guards are not within the scope of this report and are subject to evaluation and approval by the building official. Supports must satisfy the design load requirements specified in Chapter 16 of the IBC and must provide suitable material for anchorage of the rail brackets (See 5.6 under "Installation"). Where required by the building official, engineering calculations and details prepared by a licensed design professional shall be provided.

6.2.3 Compatibility of fasteners and other metallic components with the supporting structure, including chemically treated wood, is not within the scope of this report.

6.3 VEKA Vinyl Guard Systems are manufactured in accordance with the manufacturer's approved quality control system with inspections by Intertek Testing Services NA, Inc.

7.0 SUPPORTING EVIDENCE

7.1 Documentation of an Intertek approved quality control system for the manufacturing of products recognized in this report.

7.2 Drawings and installation instructions submitted by the manufacturer.

7.3 The reports of testing and engineering analysis demonstrating compliance with the performance requirements of ICC-ES AC174 "Acceptance Criteria for Deck Board Span Ratings and Guardrail Systems (Guards and Handrails)", revised December 2014.

7.4 The reports of testing and engineering analysis demonstrating compliance with the performance requirements of ASTM D7032- 21

8.0 IDENTIFICATION

The VEKA Vinyl Guard Systems are identified with the manufacturer’s name, address and telephone number, the product name, the phrase “For Use in One- and Two-Family Dwellings Only” when applicable in accordance with Table 1, the following statement: “ASTM D7032. See Intertek CCRR-0138 at <https://bpdirectory.intertek.com> for uses and performance levels.”, the Intertek Mark as shown below, and the Code Compliance Research Report number (CCRR-0138)



9.0 OTHER CODES

This section is not applicable.





10.0 CODE COMPLIANCE RESEARCH REPORT USE

10.1 Approval of building products and/or materials can only be granted by a building official having legal authority in the specific jurisdiction where approval is sought.

10.2 Code Compliance Research Reports shall not be used in any manner that implies an endorsement of the product by Intertek.

10.3 Reference to the <https://bpdirectory.intertek.com> is recommended to ascertain the current version and status of this report.

This Code Compliance Research Report (“Report”) is for the exclusive use of Intertek's Client and is provided pursuant to the agreement between Intertek and its Client. Intertek's responsibility and liability are limited to the terms and conditions of the agreement. Intertek assumes no liability to any party, other than to the Client in accordance with the agreement, for any loss, expense or damage occasioned by the use of this Report. Only the Client is authorized to permit copying or distribution of this Report and then only in its entirety, and the Client shall not use the Report in a misleading manner. Client further agrees and understands that reliance upon the Report is limited to the representations made therein. The Report is not an endorsement or recommendation for use of the subject and/or product described herein. This Report is not the Intertek Listing Report covering the subject product and utilized for Intertek Certification and this Report does not represent authorization for the use of any Intertek certification marks. Any use of the Intertek name or one of its marks for the sale or advertisement of the tested material, product or service must first be approved in writing by Intertek.



Intertek

545 E. Algonquin Road • Arlington Heights • Illinois • 60005
intertek.com/building



PCA-101



TABLE 1 – IRC ONE- AND TWO-FAMILY DWELLING GUARD ASSEMBLIES

Guard System	Rail Inserts	Rail Brackets ⁴		Balusters ⁵	Maximum Rail Length ^{1, 2, 3} (ft.-in.)
		Top	Bottom		
<i>Conrad</i>	Top Only	PVC	PVC	#1-15	10' - 0"
<i>Genova</i>	Top Only	PVC	PVC	#1-15	8' - 0"
<i>London</i>	Top Only	Nylon	Nylon	#1-15	10' - 0"
<i>Potenza II</i>	Top Only	Nylon	Nylon	#1-15	10' - 0"
<i>Prestige</i>	Top and Bottom	PVC	PVC	#16-17	8' - 0"
<i>Stanfield</i>	Top And Bottom	Aluminum or PVC	Aluminum or PVC	#1-15	8' - 0"
<i>Trustin</i>	Top And Bottom	Aluminum or PVC	Aluminum or PVC	#1-15	8' - 0"
<i>Whitman</i>	Top Only	PVC	PVC	#1-15	8' - 0"

¹ The supporting structure must be constructed to the satisfaction of the code official. See 6.2.2 under "Conditions of Use"

² Maximum rail length is measured from inside-to-inside of supports.

³ The minimum height of the top rail is 36 inches for the IRC (Section R321).

⁴ Refer to the Bracket fastening schedule and Figure 7

⁵ Refer to the Baluster schedule in Table 3. Baluster style #7 is limited to use in 36" Guard heights.

⁶ The use of these products shall be limited to exterior use as a guard system for balconies and porches for one- and two-family dwellings constructed in accordance with the IRC.





TABLE 2 – IBC GUARD ASSEMBLIES

Guard System	Rail Inserts	Rail Brackets ⁴		Balusters ⁵	Maximum Rail Length ^{1, 2, 3} (ft.-in.)
		Top	Bottom		
<i>Conrad</i>	Top Only	PVC	PVC	1-6, 8-15	8' - 0"
Deck Teck	Top ⁶ and Bottom	PVC	PVC	5, 9, 13, 14	8' - 0"
Deck Teck	Top ⁶ and Bottom	PVC	PVC	5, 9, 13, 14	6' - 0"
<i>Duralux T</i>	Top and Bottom	PVC	PVC	3-6, 8	8' - 0"
<i>Genova II</i>	Top Only	Nylon	Nylon	1-6, 8-15	8' - 0"
<i>Majestic</i>	Top And Bottom	Zinc or PVC	Aluminum or PVC	1-6, 8-15	8' - 0"
<i>Potenza</i>	Top Only	PVC	PVC	1-6, 8-15	8' - 0"
<i>Regal</i>	Top Only	PVC	PVC	1-6, 8-15	8' - 0"
<i>Stanfield</i>	Top And Bottom	Aluminum or PVC	Aluminum or PVC	1-6, 8-15	8' - 0"
<i>Stanfield II</i>	Top Only	Nylon	Nylon	1-6, 8-15	8' - 0"
<i>Trustin</i>	Top And Bottom	Aluminum or PVC	Aluminum or PVC	1-6, 8-14	8' - 0"
<i>Trustin II</i>	Top Only	Nylon	Nylon	#1-6, 8-15	10' - 0"

¹ The supporting structure must be constructed to the satisfaction of the code official. See 6.2.2 under "Conditions of Use"

² Maximum rail length is measured from inside-to-inside of supports.

³ The minimum height of the top rail is 42 inches for the IBC (Section 1015.3).

⁴ Refer to the Bracket fastening schedule and Figure 7

⁵ Refer to the Baluster schedule in Table 3.





Table 3 - Balusters

Code #	Baluster Schedule
1	1 inch square PVC picket
2	7/8 inch by 1-1/2 inch rectangular picket
3	1-1/4 inch square picket
4	1-1/2 inch square picket
5	1-1/2 inch square picket (Economy)
6	1-1/2 inch by 1-1/2 inch molded PVC spindle
7	3/4 inch galvanized powder coated iron balusters
8	1-1/2 inch fluted picket
9	3/4 inch Diameter, 0.06 inch wall, Aluminum Picket
10	3/4 inch Square, 0.045 inch wall, Aluminum Picket
11	1-1/2 inch Square LMT Series #3160 Spindle
12	1-1/2 inch Square LMT Series #3260 Spindle
13	1-1/2 inch Square LMT Series #3180 Spindle
14	1-1/2 inch Square LMT Series #3100 Spindle
15	1-3/8 inch Square PVC picket
16	3/4 inch Diameter, 0.045 inch wall, Aluminum Picket secured to each rail using a baluster plug and one #8 by 1-1/2", pan-head, self-drilling screw
17	3/4 inch Square, 0.04 inch wall, Aluminum Picket secured to each rail using a baluster plug and one #8 by 1-1/2", pan-head, self-drilling screw

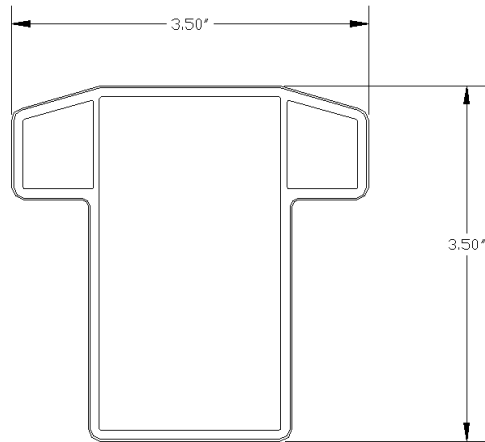



Table 4 – Fastening Schedule

Systems	Bracket	Bracket To Post	Bracket To Rail
Conrad, Majestic, Stanfield, Trustin and Whitman	PVC	Four #10 by 2-1/4" stainless steel wood screws	Four #10 by 3/4" stainless steel pan-head screws
	Zinc	Four #10 by 2" stainless steel wood screws	Two #10 by 1-1/4" stainless steel pan-head screws
	Aluminum	Six #10 by 2" stainless steel wood screws	Four #10 by 1-1/4" stainless steel pan-head screws
Regal	PVC	Four #10-10 by 1-1/2" (0.122" minor dia.) pan-head, self-drilling, zinc coated screws	Two #10-16 by 1" (0.140" minor dia.) pan-head, self-drilling, zinc coated screws
Deck Teck	PVC	Six #10-10 by 1-1/2" (0.116" minor dia.), pan-head, self-starting screws	Four #10-10 by 1-1/2" (0.116" minor dia.), pan-head, self-starting screws
Genova and Potenza	PVC	Six #10-8 by 2" (0.130" minor dia.) flathead, type 17 point, stainless steel screws	Four #10-16 by 1" (0.135" minor dia.) pan-head, self-starting, stainless steel screws
Duralux T, and Prestige	PVC	Six #10-10 by 1-1/2" (0.122" minor dia.) pan-head, self-drilling, zinc coated screws	Two #10-16 by 1" (0.140" minor dia.) pan-head, self-drilling, zinc coated screws
Genova II, London, Potenza II, Stanfield II, and Trustin II	Nylon	Four #10-8 by 2" (0.130" minor dia.) bugle head, type 17 point, stainless steel screws	Two #10-16 by 1" (0.140" minor dia.) pan-head, self-drilling, zinc coated screws





Top Rail: Conrad/Trustin/Trustin II /Deck Teck/Potenza Potenza II/Duralux T/Prestige

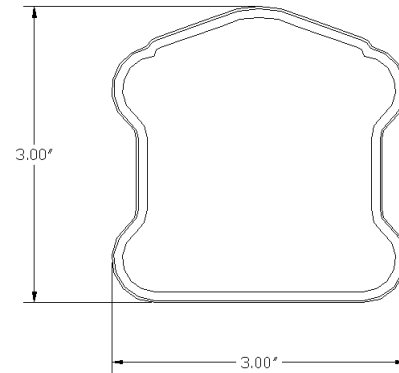

Top Rail: Regal/Majestic

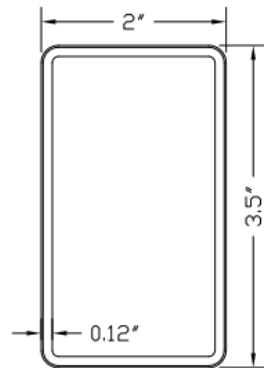

Top Rail: Stanfield/Whitman/Genova

Bottom Rail: Whitman/Majestic/Conrad/Stanfield/Trustin/Genova/Potenza/Deck Teck

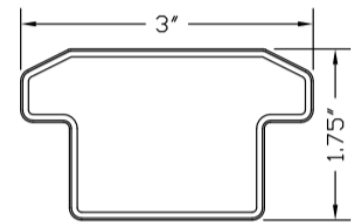

Top Rail: London

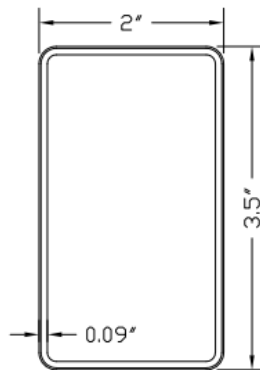

Top Rail: Genova II/Stanfield II

Bottom Rail: Genova II/Potenza II/Regal/Stanfield II/Trustin II/London/Duralux T/Prestige

FIGURE 1 – PVC RAIL PROFILES

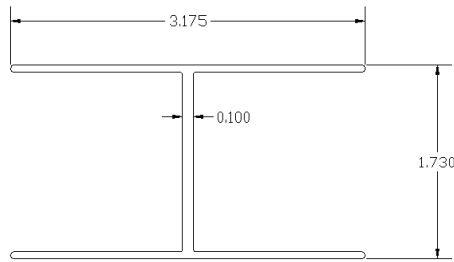

Top Rail: *Conrad, Stanfield, Trustin and Whitman*
Bottom Rail: *Majestic, Stanfield, and Trustin,*

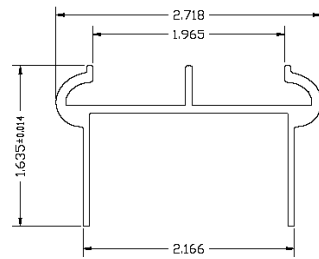

Top Rail: *Regal and Majestic*

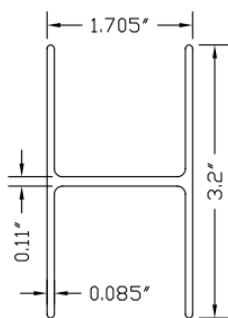

Top Rail: *Stanfield II, Trustin II*

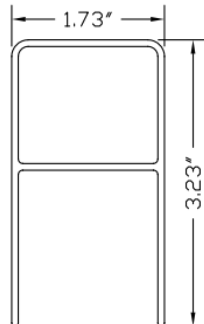

Top Rail: *Genova, Genova II, Potenza, Potenza II*

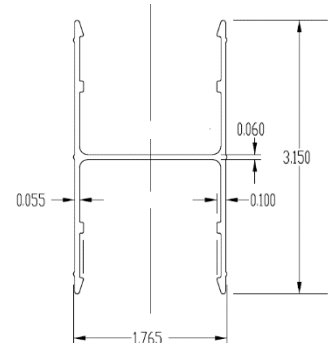

Top Rail: *Deck Teck (8 foot length)*

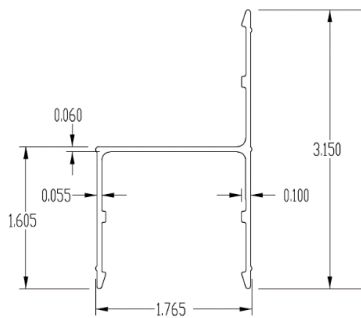

Top Rail: *Deck Teck (6 foot length)*

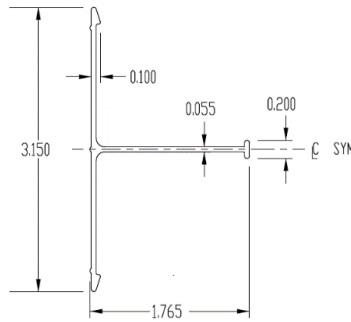

Bottom Rail: *Deck Teck*

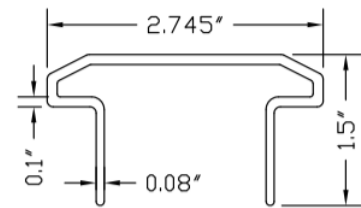

Top Rail: *London*

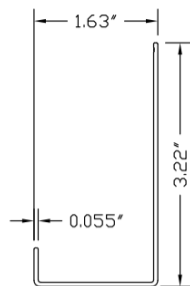

Top Rail: "J" orientation for *Prestige*
Bottom Rail: "7" orientation for *Prestige*

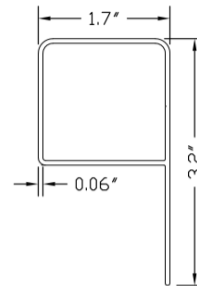

Top Rail: "P" orientation for *Duralux T*
Bottom Rail: "d" orientation for *Duralux T*

FIGURE 2 - ALUMINUM RAIL INSERTS

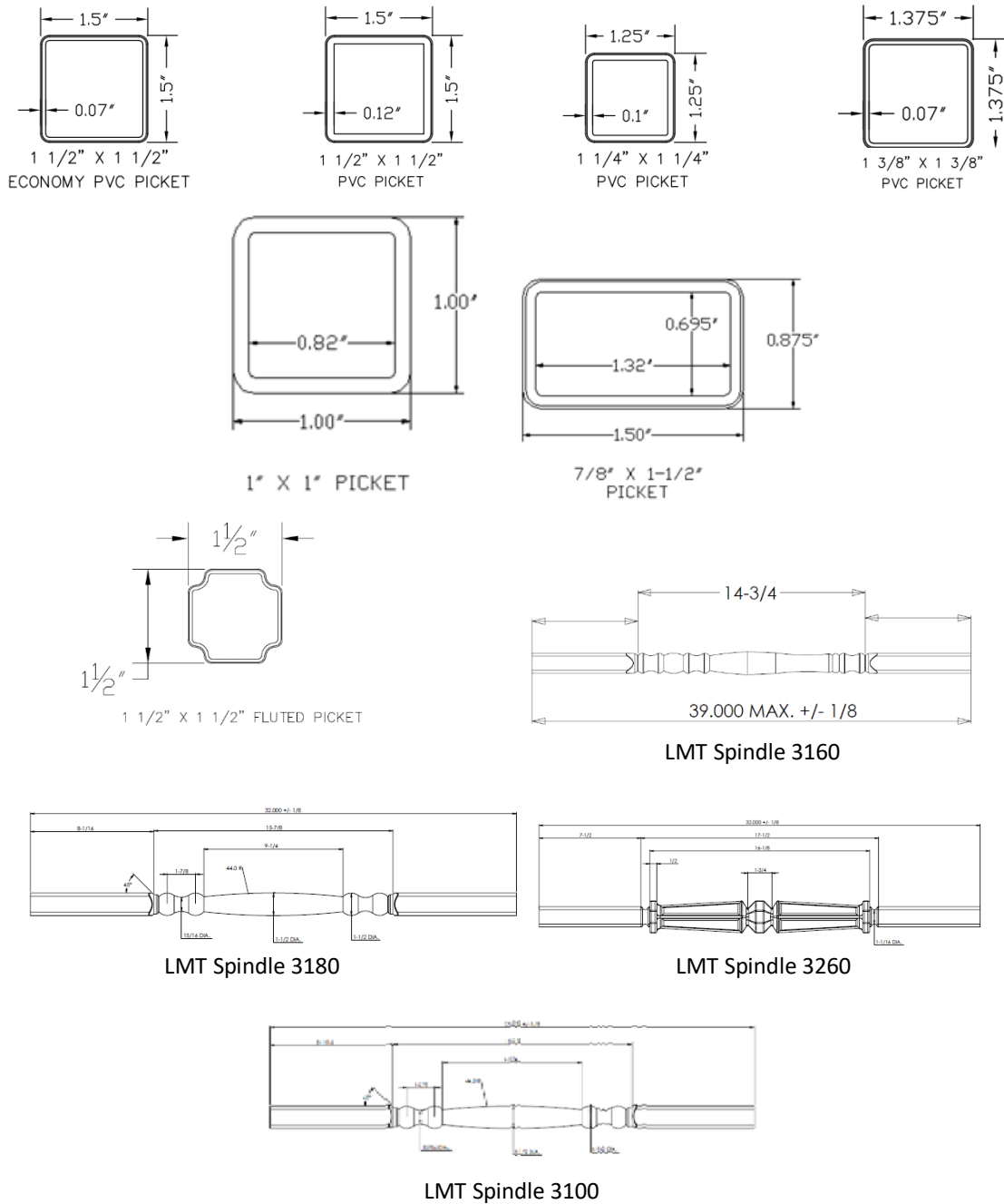

FIGURE 3 – PVC BALUSTERS



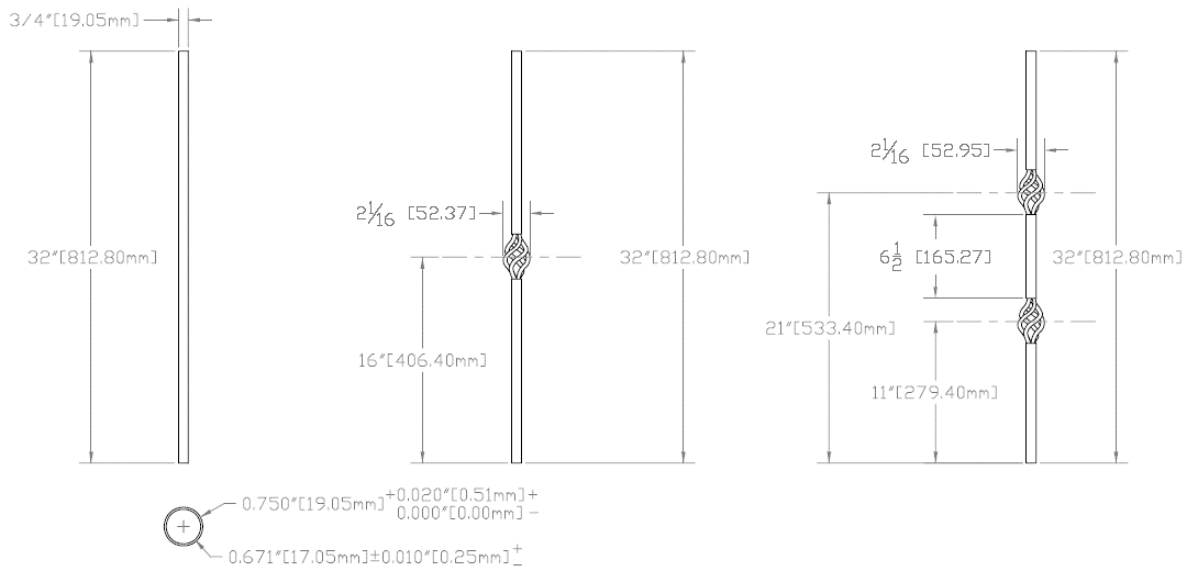
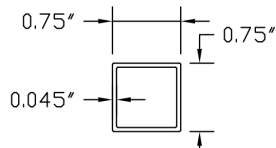
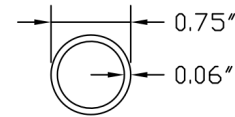

FIGURE 4 – IRON BALUSTERS



3/4 inch Diameter, 0.06 inch wall, Aluminum Picket



3/4 inch Square, 0.045 inch wall, Aluminum Picket

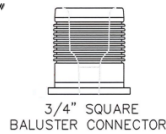
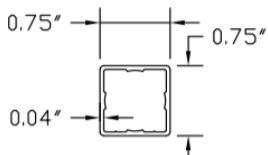

3/4 inch Diameter, 0.045 inch wall, Aluminum Picket

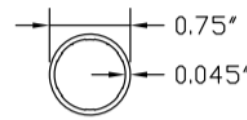

3/4 inch Square, 0.04 inch wall, Aluminum Picket

FIGURE 5 – ALUMINUM BALUSTERS

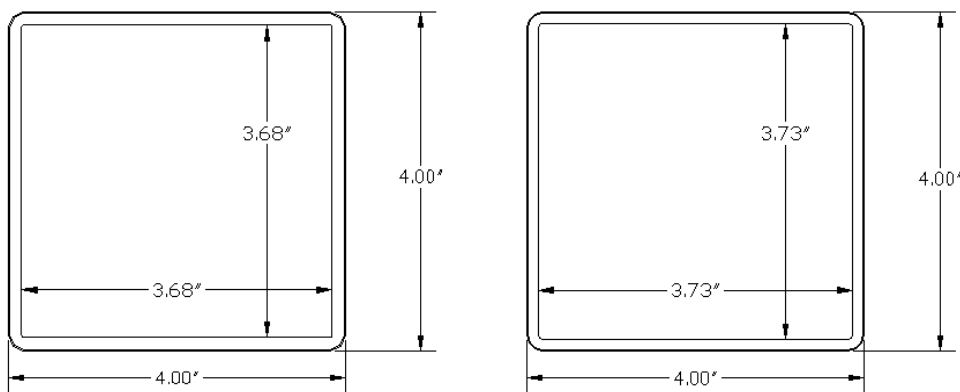
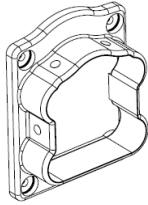
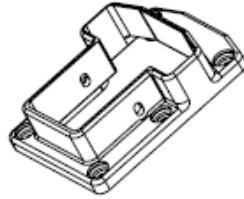

FIGURE 6 – POST SLEEVES



Majestic/Regal
Top PVC Bracket



Conrad/Duralux T/Prestige
Top PVC Bracket

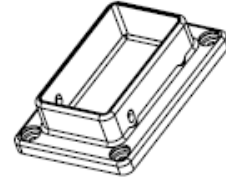

Whitman Top and Bottom Bracket
Conrad/Regal/Duralux T/Prestige Bottom Bracket

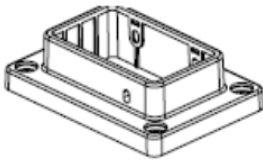

Deck Teck
Bottom Bracket

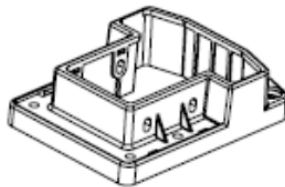

Deck Teck
Top Bracket

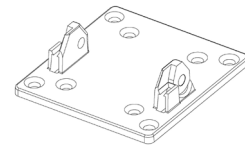

London
Top Nylon Bracket

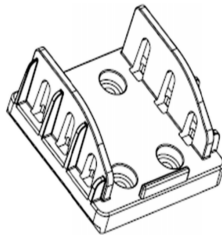

Stanfield II/Genova II/Trustin II/Potenza II
Top and Bottom Nylon Bracket
London Bottom Nylon Bracket

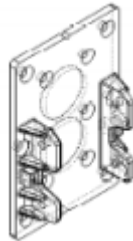

Potenza/Trustin
Top PVC Bracket

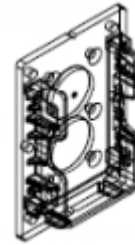

Genova/Stanfield Top and Bottom PVC Bracket
Potenza/Majestic/Trustin Bottom PVC Bracket

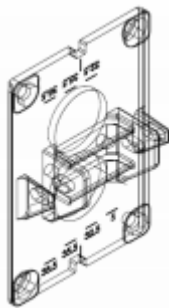

Majestic
Top Zinc Bracket

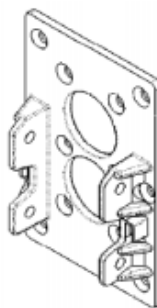

Trustin
Top Aluminum Bracket

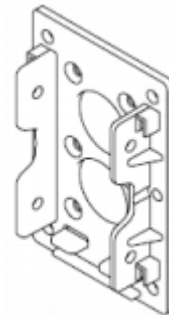

Stanfield Top and Bottom Aluminum Brackets
Trustin and Majestic Bottom Aluminum Bracket

FIGURE 7 – BRACKETS